

EURO6

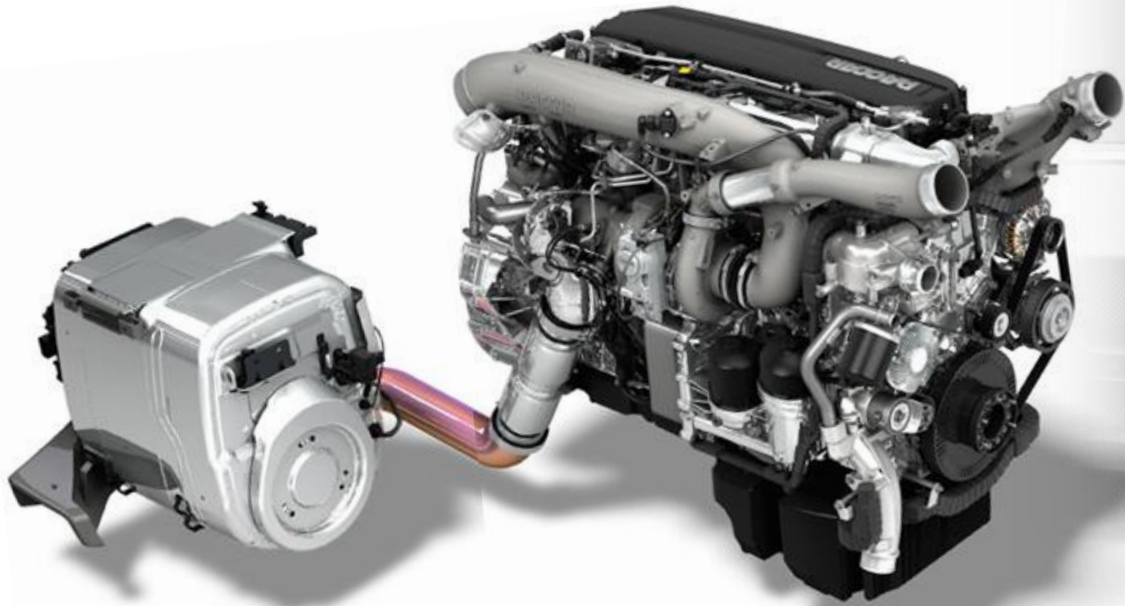

DAF

most advanced diesel technology made available for IWT



OFFICIEEL DEALER



BIJ KONINKLIJKE BESCHIKING
HOFLIVERANCIER



Power Ratings Propulsion

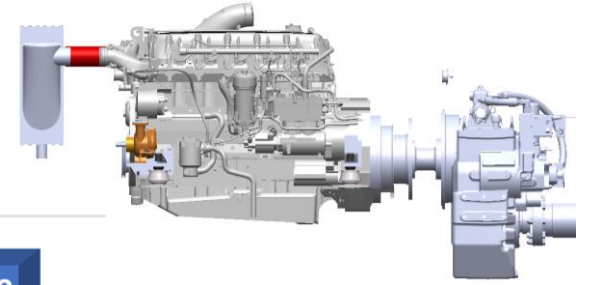

MX-11



→ Engine power (kW)

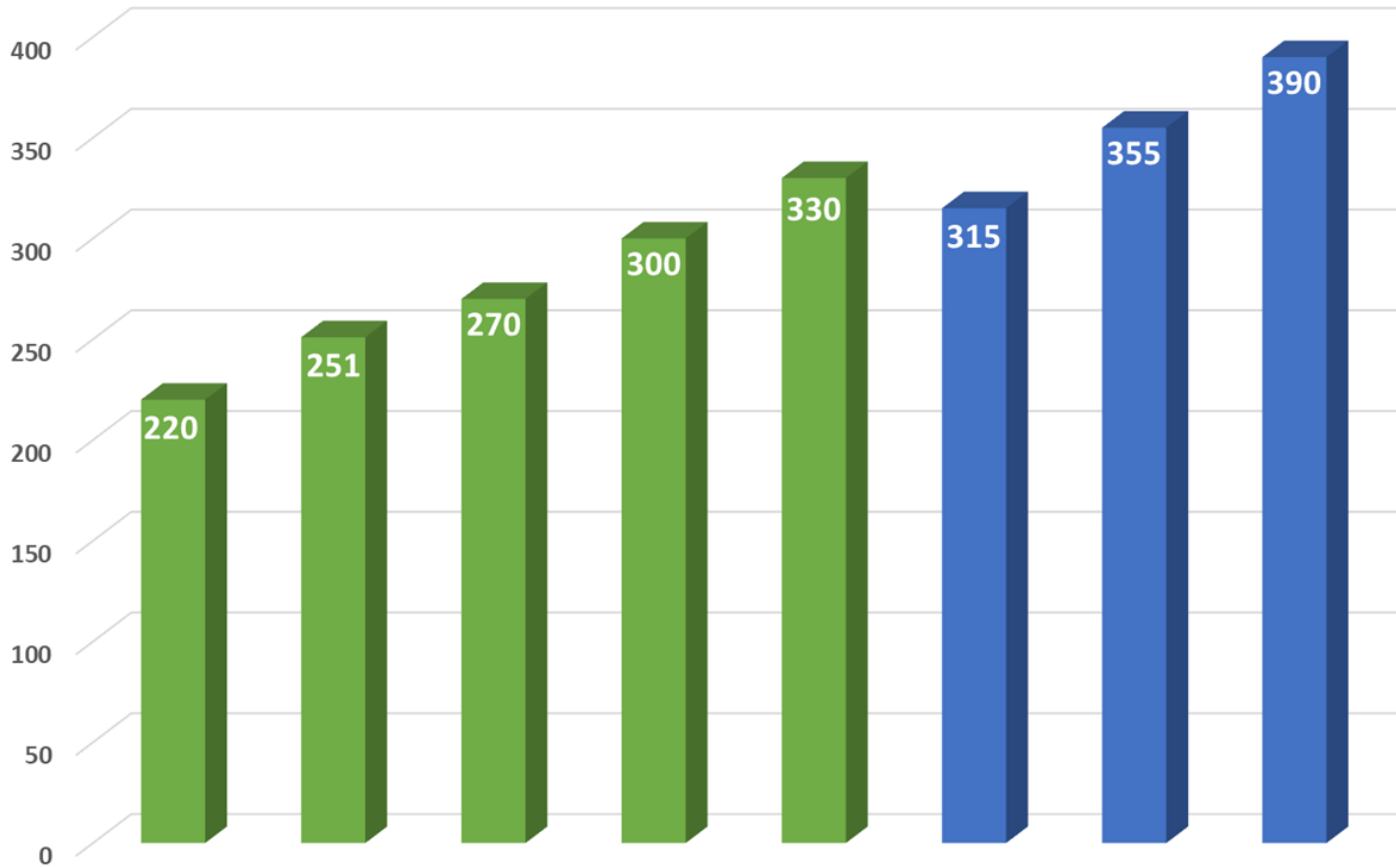

MX-13





Power Ratings Gensets

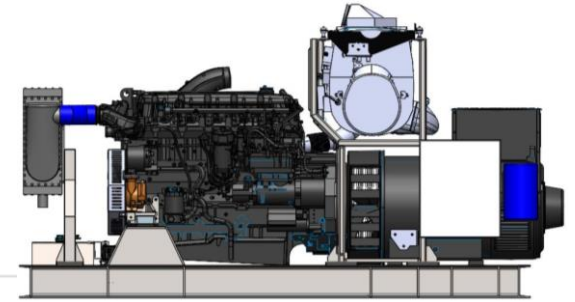

MX-11



→ Genset power (kVa @ Cos phi 0,8)

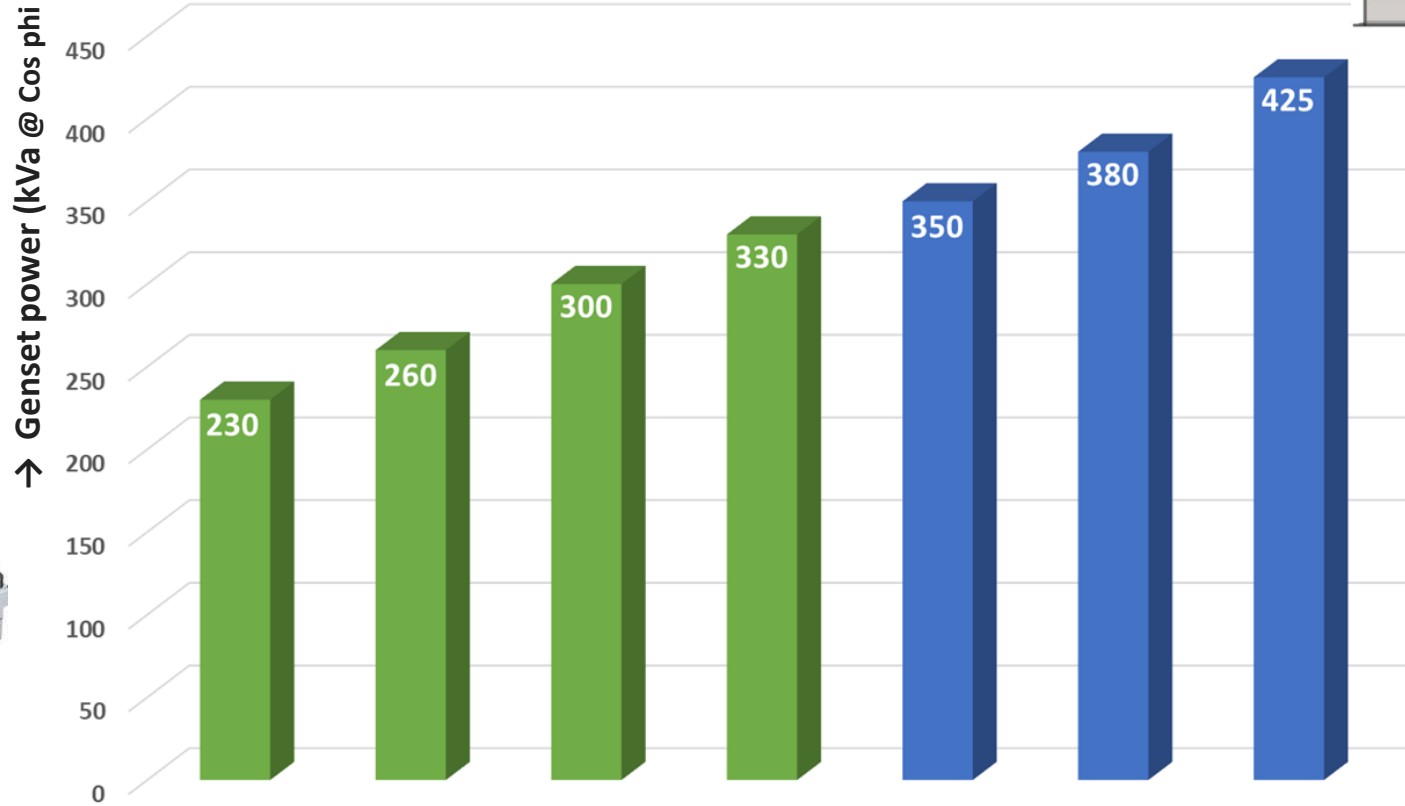

MX-13





Availability



Eindhoven

270

engines per day

200

trucks per day -/-

70

OEM engines per day

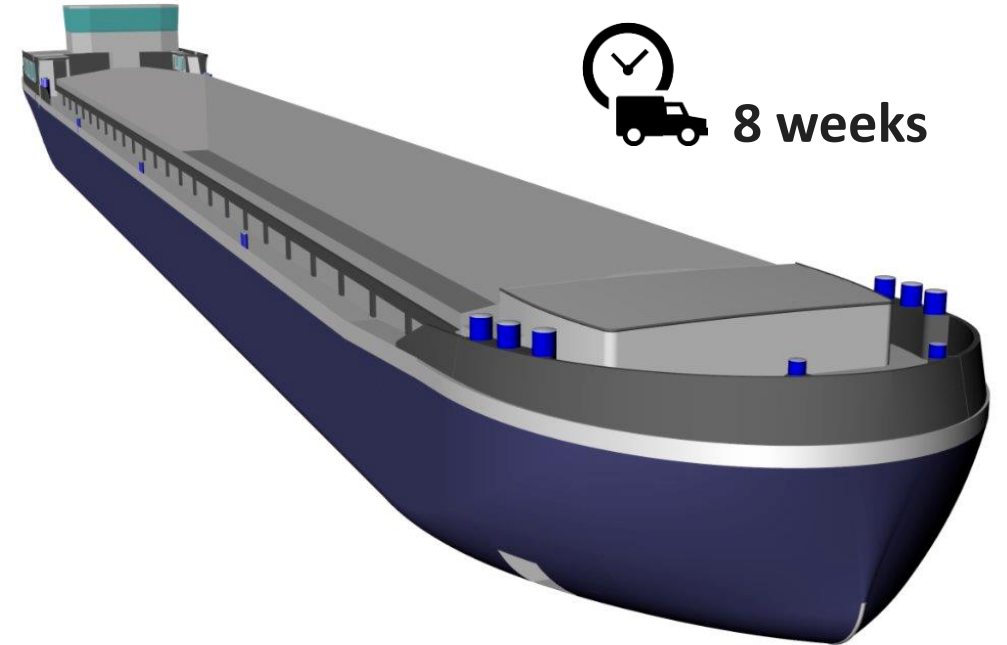

8 weeks





Alternative Fuels



EN 15940



EN 16709 (FAME)





H2-ICE



- Single fuel H2
- Zero CO₂
- EuroVI engine platform
- Low quality H2
- Non toxic fuel
- No aftertreatment
- HC to H2 conversion kit
- First deliveries Q4 2023

“Spits Kempenaar Neokemp Dortmund Rijn-Herne”



Westropa 39,00 X 5,10 single propshaft



200-300kW

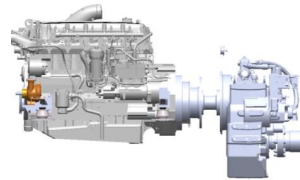

Neokemp 63,00 X 7,30 double propshaft



2x300kW

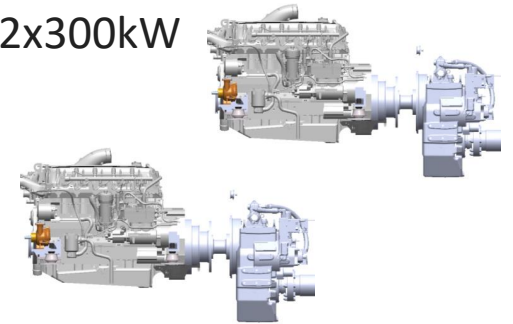

Estero 56,00 X 6,60 single propshaft



300-400kW

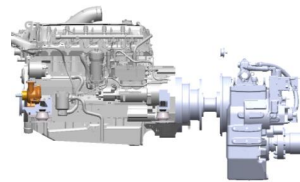

Wantij 86,00 X 9,00 double propshaft



2x350kW

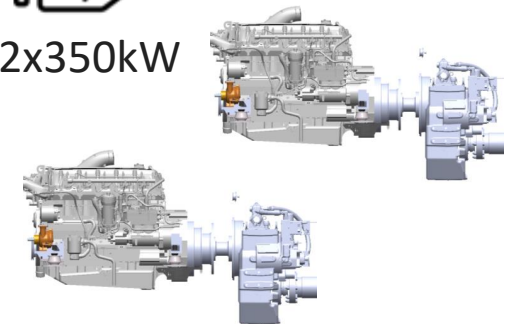

“Duijvendijker”



Mariëtte 89,00 X 9,50 single propshaft

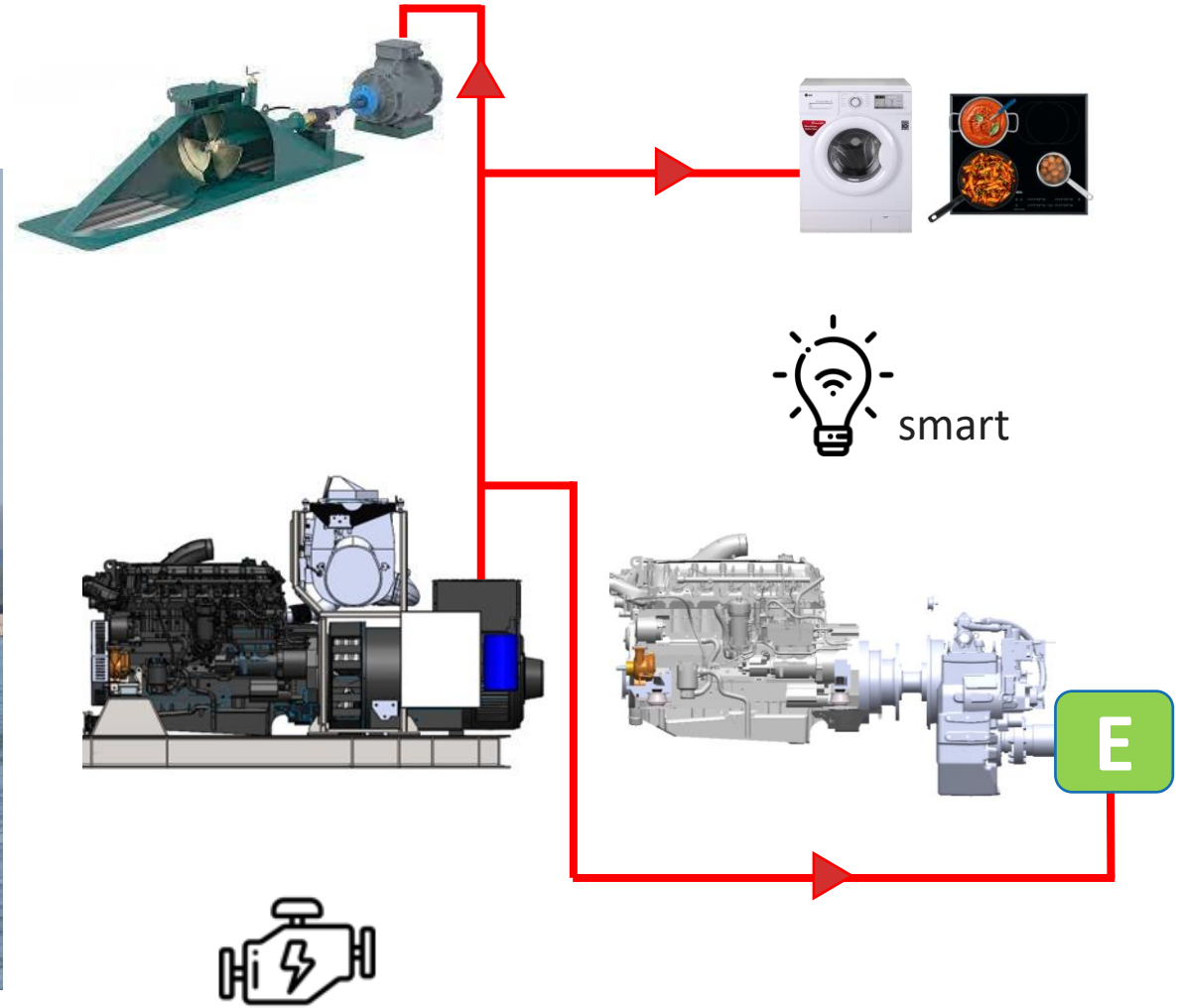

1x400kW + 1x315kW genset



“Tanker”



Nesselande 86,00 X 9,10 single propshaft



1 set 2x400kW

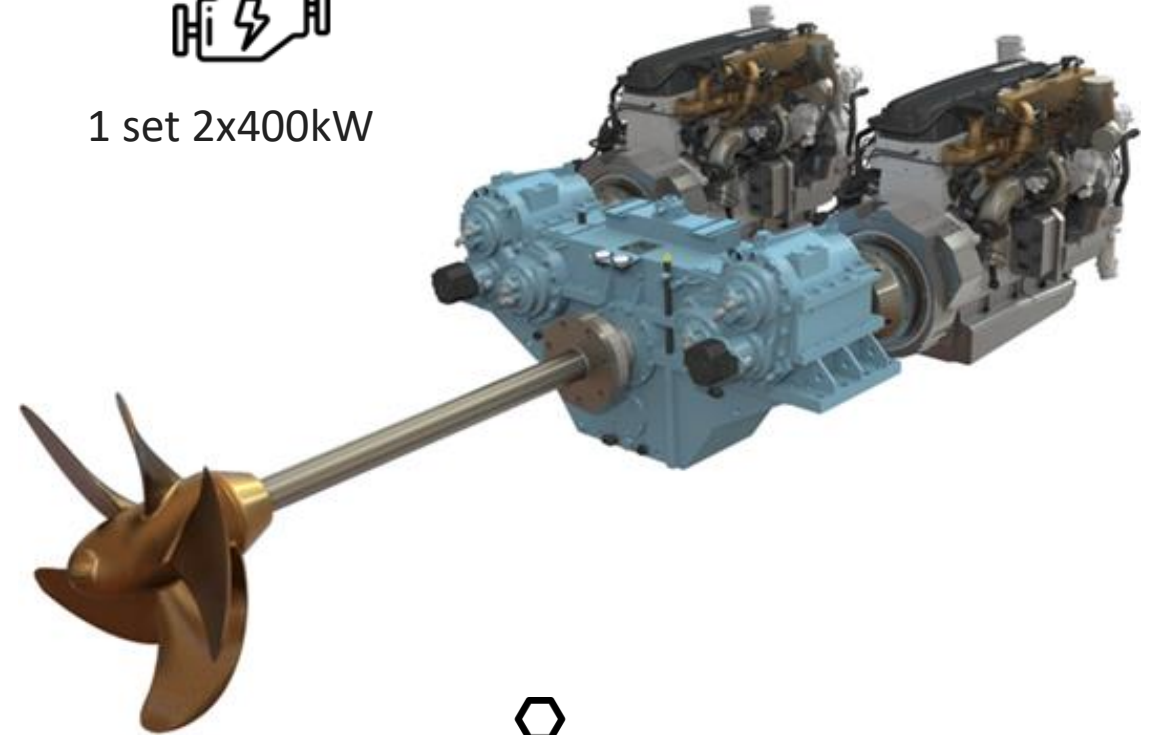

modular

“Rhinevessel Tanker Containervessel”

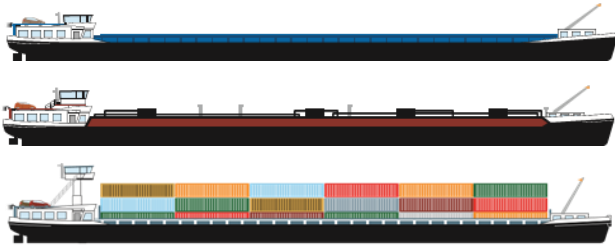

110/135 X 11,40 double propshaft

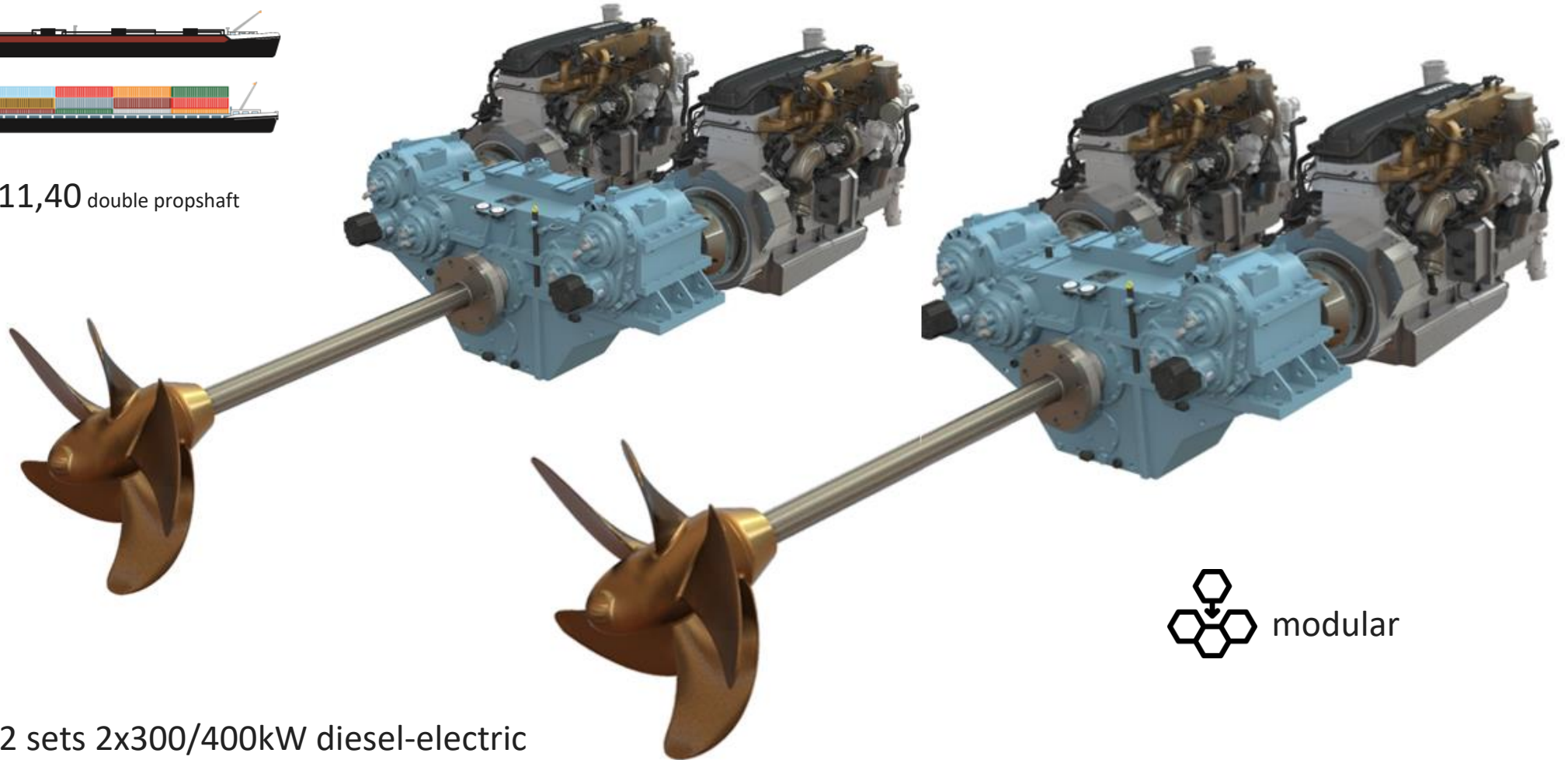

2 sets 2x300/400kW diesel-electric



“Pushbarge Pushcombination”



172 X 11,40 double/triple propshaft



185 X 11,40 double/triple propshaft

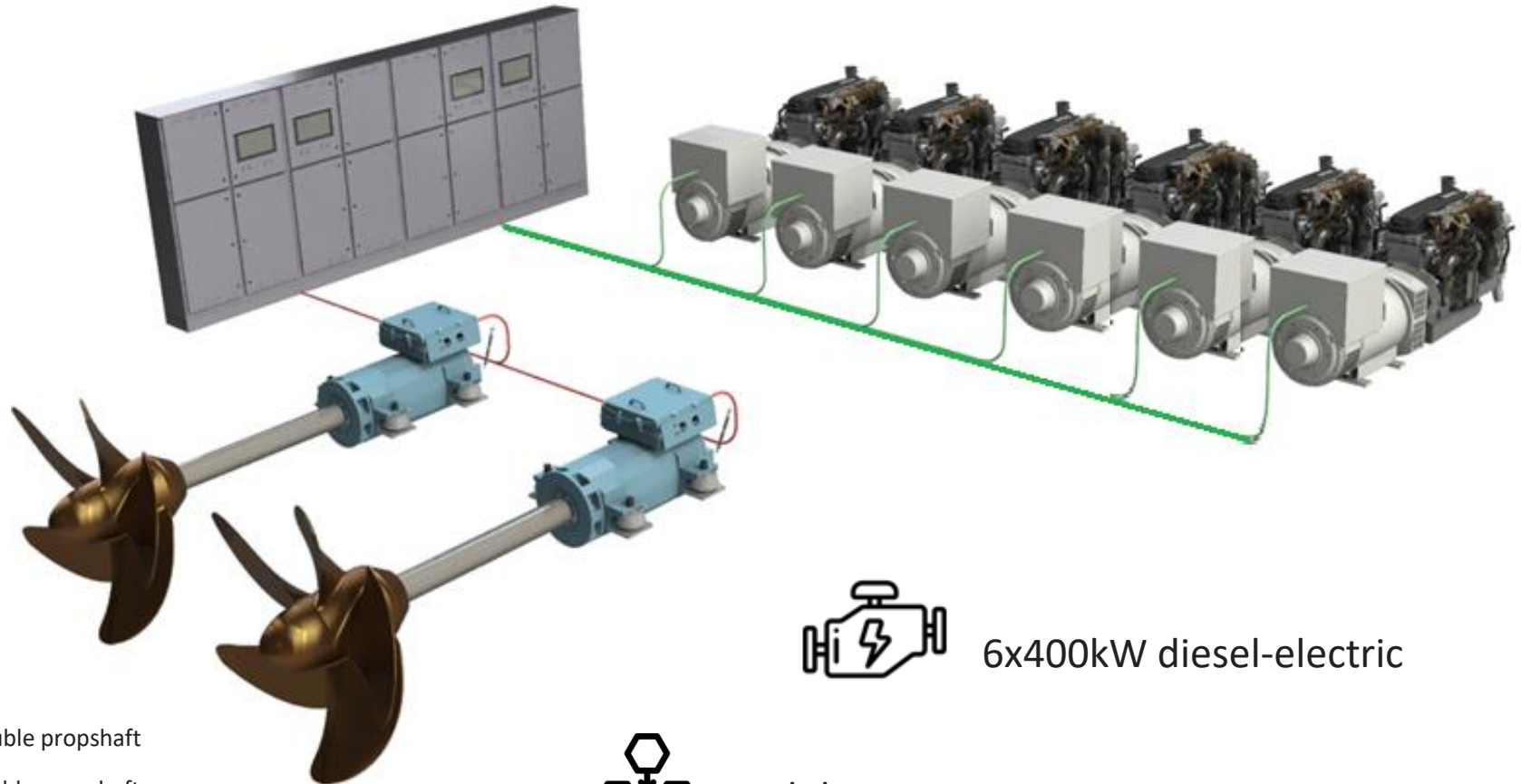

6x400kW diesel-electric



modular

Rhenus Mannheim 1+2 185 X 11,40 double propshaft
Rhenus Wörth 1+2 185 X 11,40 double propshaft



“Operational impact”



- DAF engine + aftertreatment “One Stop Shop”
- Availability + aftersales network
- Compact aftertreatmentsystem
- Modular setup = efficiency ↑
- EuroVI → IWP ↔ IWA
- Alternative fuels
- HC to H2 kit
- EuroVII



- Maximum power rating
- Sailing profile “Spits”



- 4/6 barge pushcombinations

Stenn Hertgers

Sales Manager

Vink diesel bv

Rivierdijk 76
3361 AR Sliedrecht

T +31(0)184 415 455

M +31(0)6 82762266

sales@vinkdiesel.nl

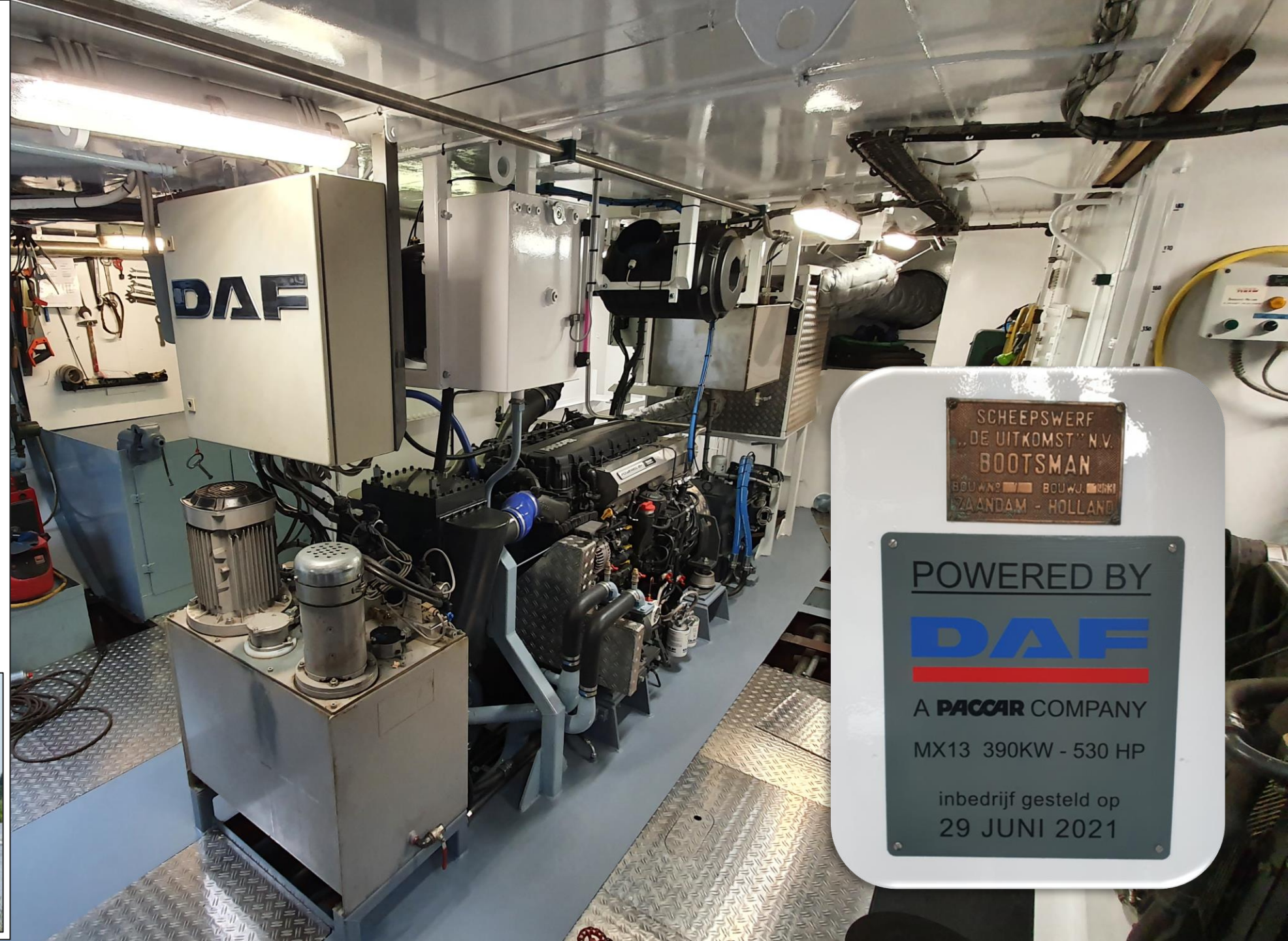

SCHEEPSWERF
DE UITKOMST N.V.
BOOTSMAN
BOUWNO BOUWJ. WIKRI
ZAANDAM - HOLLAND

POWERED BY

DAF

A PACCAR COMPANY

MX13 390KW - 530 HP

inbedrijf gesteld op
29 JUNI 2021